

# MAGNETIC HEAD FOR CARD USE

## DUAL TRACK LOW PROFILE READER

### MODEL TG200 SERIES



Ceramic Head

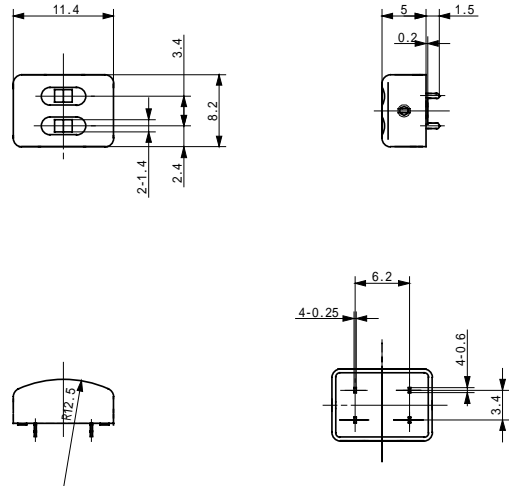

### FEATURE

Low profile head . Compact size gives flexibility in card reader designing.

ISO 1-2 track and 2-3 track.

Standard min.500k passes and optional min.1,000k or super-long life of 4,000k passes are available.

Other custom electric specifications are available in this series.

### APPLICATION

ISO dual track reader.

Manual card reader for ID control.

### ELECTRICAL & PHYSICAL SPECIFICATIONS

ITEMS	MEASURING CONDITIONS	TG200	CUSTOMER MODEL
D.C. resistance		110 ± 20%	± %
Inductance	1KHz 100 μ	25mH ± 20%	mH ± %
Read output		20mVp-p ± 25%	mVp-p ± %
Measuring tape	Recording density 210BPI/Speed	Maxell PM50-7B/7.5ips	Maxell PM50-7B/7.5ips
Track & Gap width		1.4mm/30 μ m	1.4mm/30 μ m
Permalloy cores	Min. passes guaranteed	500k	500k
Sendust cores	As above	1,000k	1,000k
Ceramic treatment	As above	4,000k	4,000k

## TECHRECO CO., LTD.

3-8-8 HAMACHO KAWASAKI-KU KAWASAKI-CITY JAPAN 210-0851

TEL:81-44-355-6161 FAX:81-44-355-6167

For more information & inquiry: [sales@techreco.co.jp](mailto:sales@techreco.co.jp)

<http://www.techreco.co.jp>