

# MAGNETIC HEAD FOR CARD USE

## MICR HEAD

### MODEL TG8181 SERIES

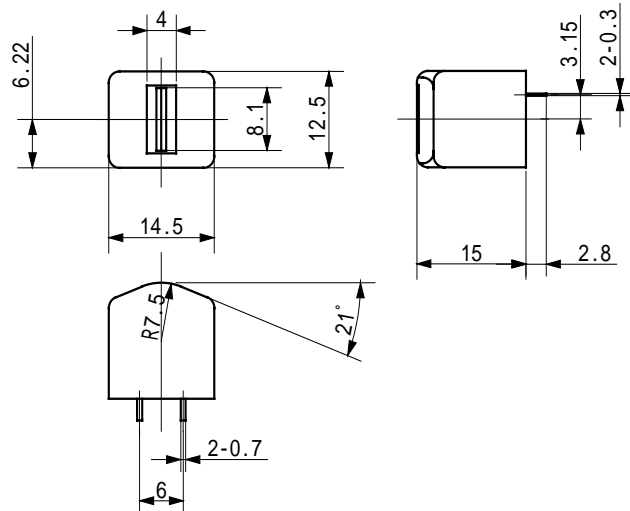

### FEATURE

- Original design of head contour guarantees optimum reading performance.
- Standard min.500k passes guaranteed.
- Other custom electric specifications are available in this series.

### APPLICATION

- Magnetic Ink Card Reader (MICR).
- Applicable to both E13B & CMC7.

### ELECTRICAL & PHYSICAL SPECIFICATIONS

ITEMS	MEASURING CONDITIONS	TG8181	Custom Model
D.C. resistance		450 ± 20%	± %
Inductance	1KHz 100 μ	335mH ± 20%	mH ± %
Read output		250mVp-p ± 25%	mVp-p ± %
Measuring tape	Recording density 210BPI/Speed	Maxell PM50-7B/10ips	Maxell PM50-7B/10ips
Track & Gap width		8.1mm/25 μ m	8.1mm/25 μ m
Permalloy cores	Min. passes guaranteed	500k	500k

## TECHRECO CO., LTD.

3-8-8 HAMACHO KAWASAKI-KU KAWASAKI-CITY JAPAN 210-0851

TEL:81-44-355-6161 FAX:81-44-355-6167

For more information & inquiry: [sales@techreco.co.jp](mailto:sales@techreco.co.jp) <http://www.techreco.co.jp>